

**PARTS INFORMATION**

**Contents of Kit P/N 71 60 0 303 878**

<b>Description</b>	<b>Qty</b>	<b>BMW Part Number</b>
Cross Member with Receiver Tube	1	71 60 0 303 880
Cross Member Mounting Nuts	4	07 11 9 904 026
White Capacities Sticker	1	82 11 0 306 482
Receiver Tube Cover/Cap	1	71 60 0 303 882
Electrical Kit	1	71 60 0 303 881
Contents of Electrical Kit:		
Lighting Control Module	1	61 35 6 908 767
Vehicle-Side Wiring Harness	1	Part Number Not Available
7-pin Trailer Wiring Connector	1	Part Number Not Available
7-pin to 4-pin Trailer Wiring Adapter	1	Part Number Not Available
Hardware Kit	1	Part Number Not Available

**Additional Required Parts**

<b>Description</b>	<b>Qty</b>	<b>BMW Part Number</b>
Ball Mount Kit	1	71 60 0 303 879

**Location of Kit Parts**

Illustration S71 03 U24 shows the location of the major components/connections of the X3 Trailer Hitch System.

**A = Trailer Hitch Receiver**

**B = Vehicle Connector for Installation Kit 7-pin Connector Wiring Harness**

**C = Lighting Control Module**

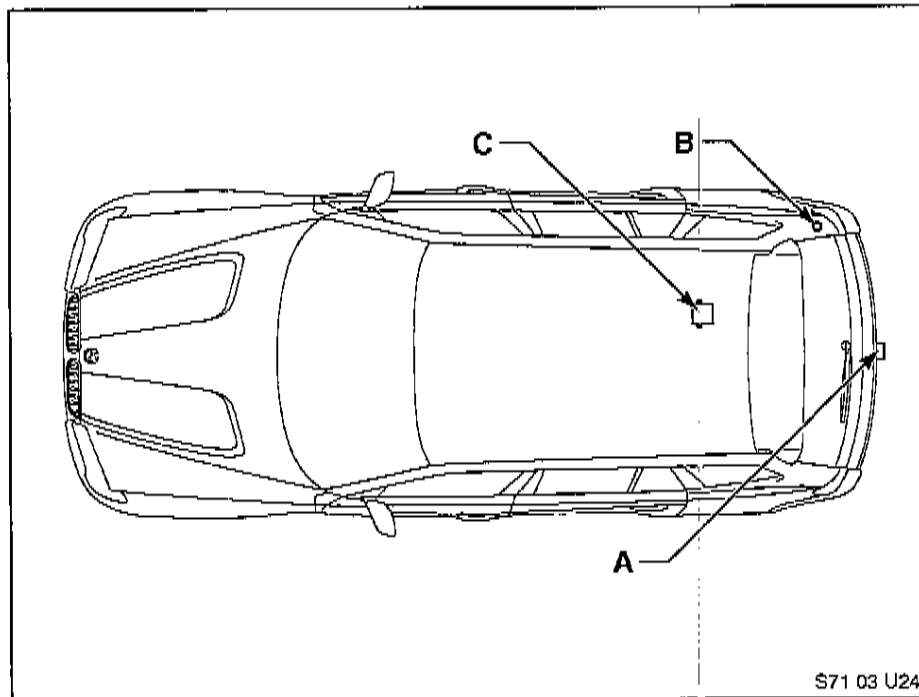

**Procedure**

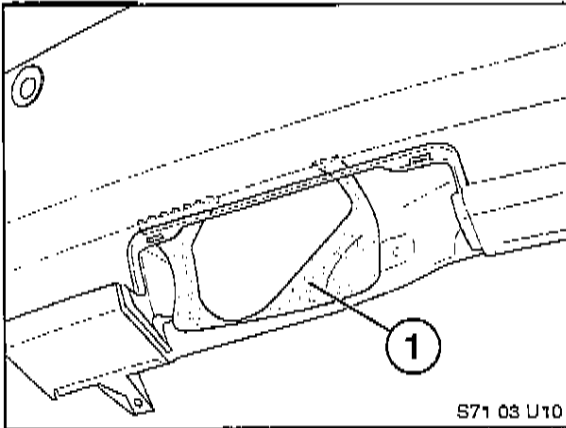

1. Remove rear bumper trim from vehicle per (TIS) RA 51 12 156.

Remove and discard center mounted cover/trim plate from bumper fascia.

Locate trailer hitch receiver tube/connector bracket cutout (1) outlined on inner surface of bumper fascia insert.

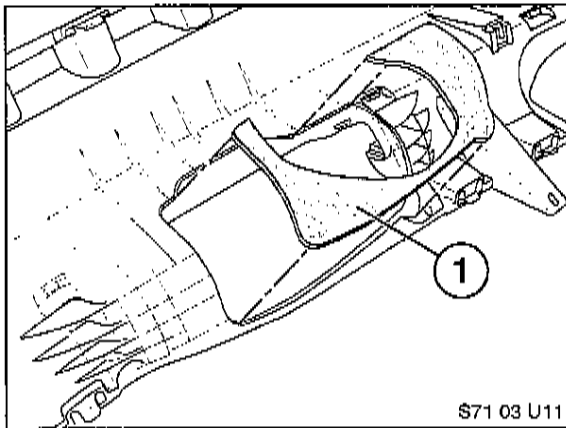

2. Use a small reciprocating saw [such as Snap-on No. AT 192/193 series] to remove cut-out material (1) as illustrated.

Use a variable speed rotary tool and a file to clean and smooth cut edges of bumper fascia insert.

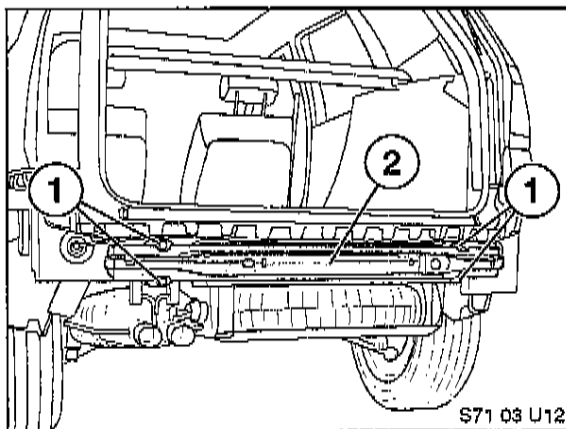

3. Remove and discard the four mounting nuts (1) and steel bumper (2) from vehicle.

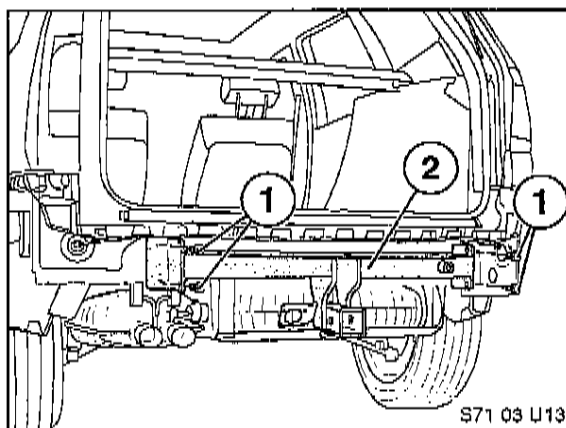

4. Install trailer hitch (2) using four new nuts (1) from installation kit.

Important: Torque nuts to 71Nm Reference (TIS) RA 51 12 050.

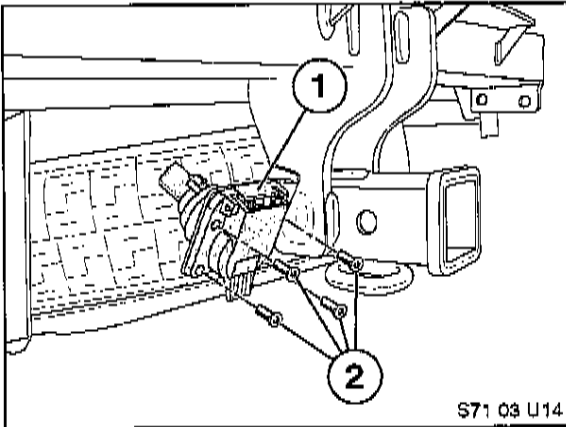

5. Install 7-pin trailer connector (1) onto mounting plate as illustrated with four T25 TORX® head screws (2) from installation kit.

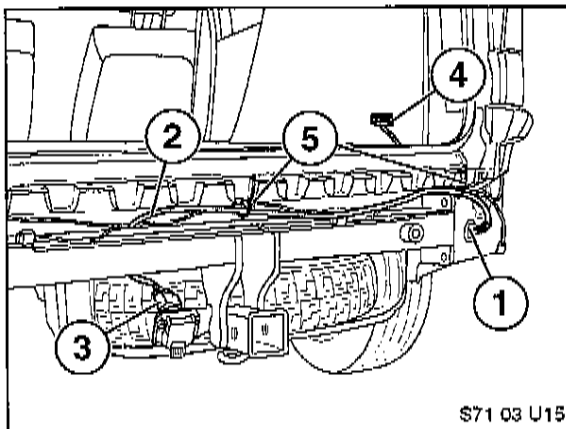

6. Remove cargo floor / spare tire cover from vehicle interior.

Hint: If vehicle so equipped loosen right side cargo tie-down rail to swing rear section of rail approximately 20mm towards centerline of vehicle.

Remove right side corner tray / storage well trim panel cover.

Remove sealing plug from (1).

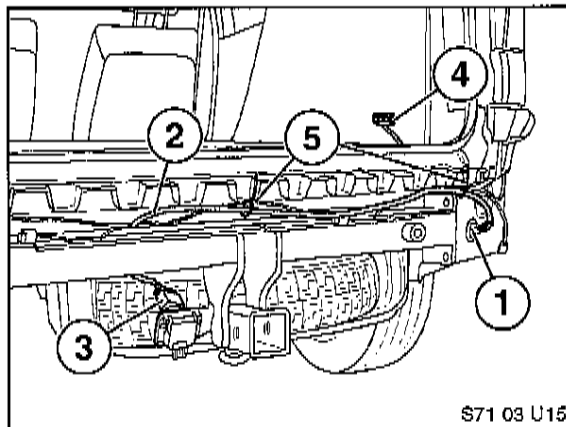

7. Route trailer wiring harness from kit (2) behind & across top of hitch, along vehicle PDC harness, through hole in body (1), into vehicle interior so that connector (4) is located in right rear corner storage area.

Secure trailer harness to vehicle PDC harness with four wire-ties (5) from kit.

Connect trailer wiring harness connector (3) to 7-pin trailer connector. Reference illustration S71 03 U25.

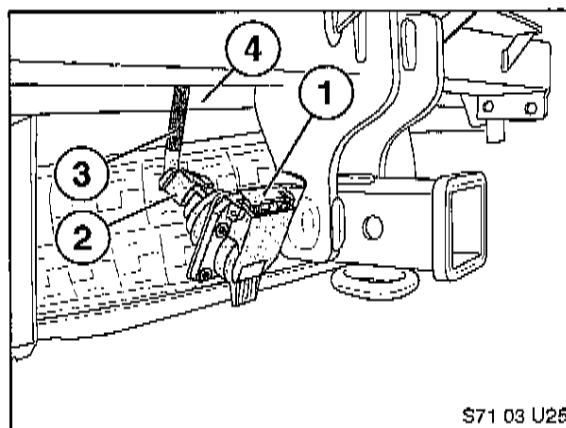

8. Connect trailer wiring connector (2) to trailer connector (1).

Important: Make certain harness connector (2) is fully seated and red locking tab is in full locked (closed) position.

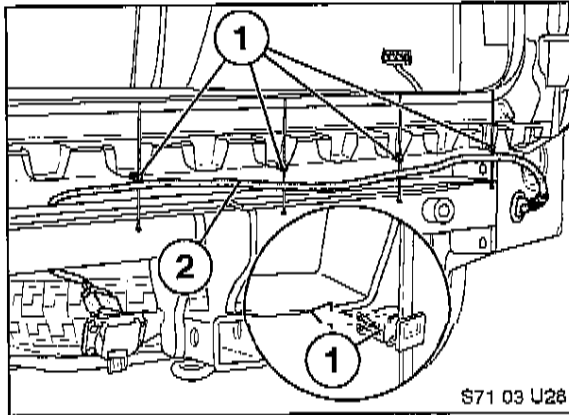

9. If vehicle is not equipped with PDC (or as alternate trailer wiring harness routing option) secure trailer wiring harness (2) to vehicle plastic bumper guide with wire-tie clip assembly (1) as illustrated.

Note: For vehicles equipped with PDC, clip can be removed and wire-tie used in the conventional manner.

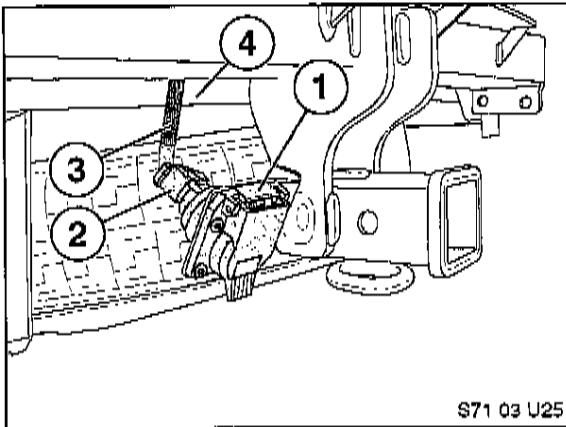

10. Important: Wrap trailer wiring harness several times with a 2 inch wide piece of duct tape (3) in the area where the harness passes along the edge of the vehicle body panel (4). This will add an additional layer of protection to the harness.

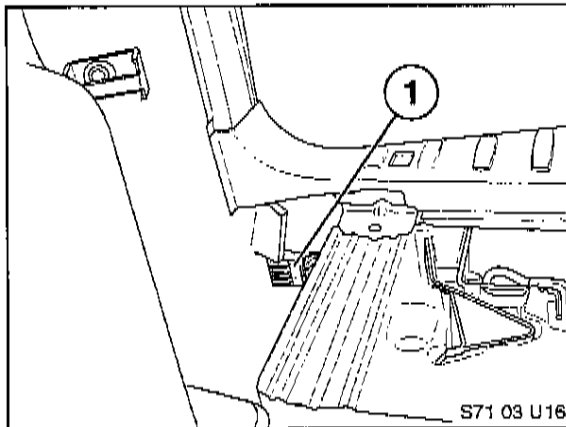

11. Locate vehicle connector (1) in right side storage well area.

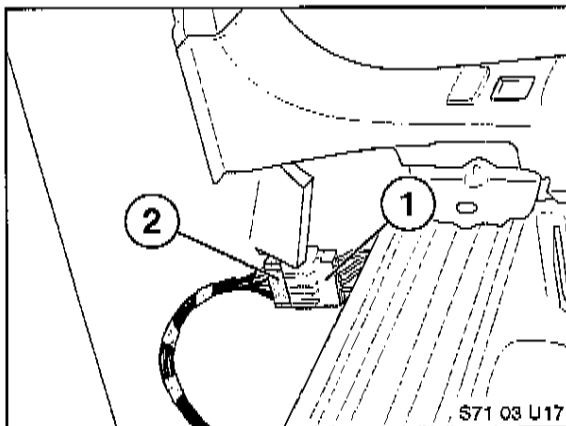

12. Plug trailer hitch wiring harness connector (2) into vehicle connector (1).

Route excess harness cable behind sound insulation material.

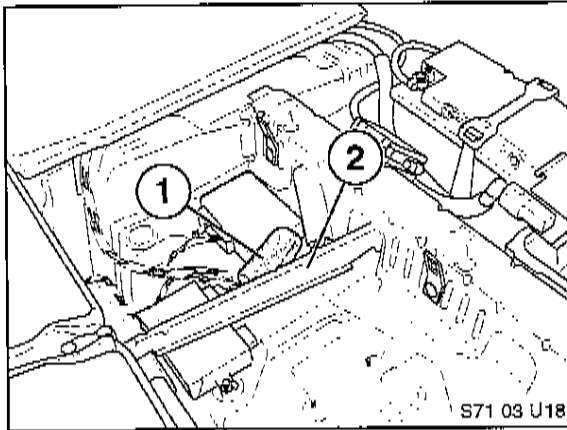

13. Remove/lift up cargo area forward floor panel located just behind rear seats. Reference (TIS) RA 61 35 000.

Locate and un-wrap lighting control module harness and connector (1). Hint: Foam wrapped connector should be located just under or next to longitudinal brace (2).

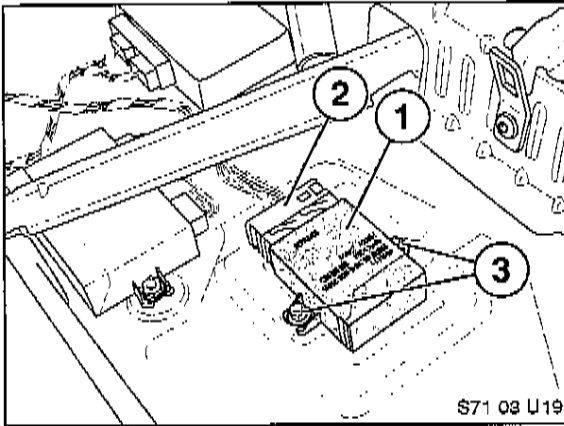

14. Mount lighting control module (1) from kit as illustrated using two plastic nuts (3) from kit. Note: Plastic nut P/N is 16 13 1 176 747.

Carefully route harness and connector under longitudinal brace [reference illustration S71 03 U18, item (2)] and connect to lighting control module. Make certain harness does not rub against brace.

Use wire-tie from kit to secure harness as needed.

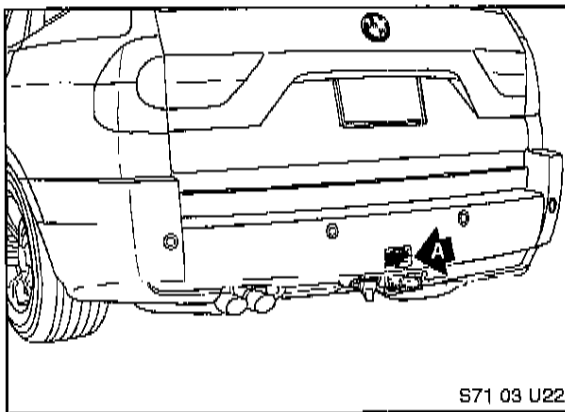

15. Reinstall bumper fascia and vehicle interior components.

Note: Clean bumper with a mild cleaner and or alcohol in the area where sticker (A) is to be positioned.

Important: Install white Capacities Sticker (A) from installation kit onto bumper fascia centered just above trailer hitch receiver tube as illustrated.

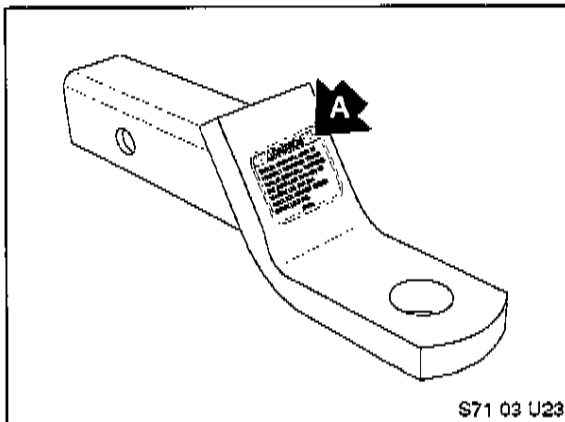

16. Important: Make certain silver Caution Sticker (A) is located on ball mount as illustrated.

Note: Silver caution sticker is **not** available as a separate part.

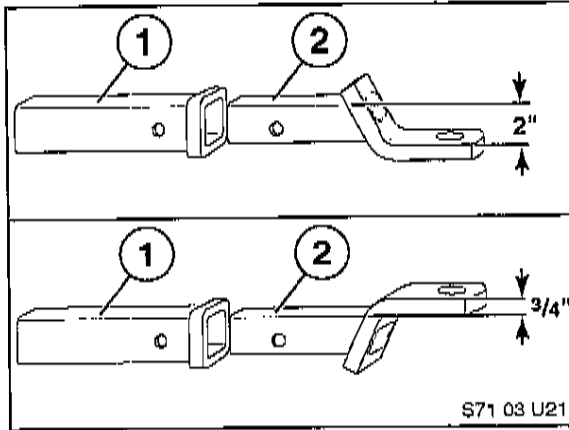

17. Important: Use only the BMW X3 ball mount available from BMW Centers with a maximum 2 inch drop or 3/4 inch rise as illustrated.

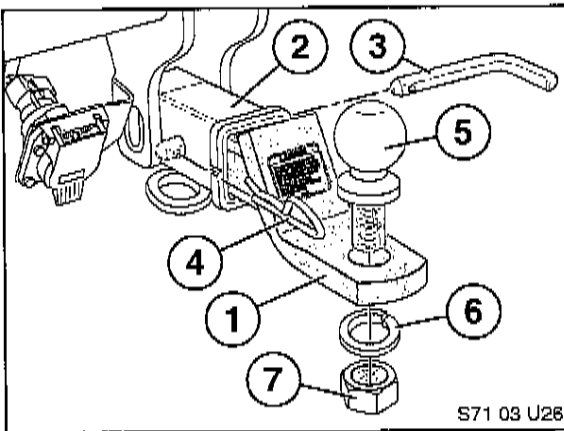

18. Install trailer ball (5) to ball mount (1) with lock washer (6) and nut (7).

Important: Torque nut to 250 foot lbs. (340Nm).

Reference information and warnings on ball mount sticker.

Install ball mount assembly (1) into trailer hitch receiver tube (2) by aligning holes in mount and tube and inserting pin (3) and clip (4) as illustrated.

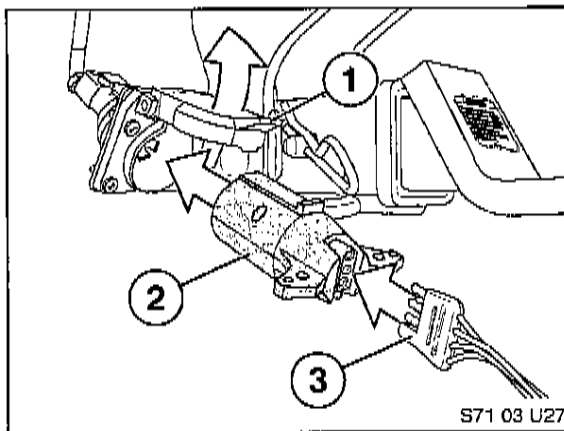

19. When towing a trailer with a four-pin wiring harness (3). Use the 4-pin to 7-pin adaptor (2) included in the installation kit to connect the trailer electrical system to vehicle connector (1).

The adapter should be kept with vehicle at all times.

**THE INSTALLATION PROCEDURE IS COMPLETE.**

**SEE PAGES 9 and 10 FOR CUSTOMER GUIDELINES / CAUTIONS SHEETS TO BE LEFT IN VEHICLE FOR CUSTOMER REFERENCE.**

## BMW X3 Trailer Hitch Guidelines and Cautions

Page 1 of 2

These Guideline Sheets should be left in the vehicle (for customer reference) after installation of the Trailer Hitch

- The BMW X3 Trailer Hitch is rated **Class 2** (gross trailer weight 3500 lbs., maximum tongue weight 350 lbs.). **Never** exceed those specifications. This rating is based on a standard equipped vehicle with driver. Additional passengers and/or cargo will reduce maximum vehicle/trailer ratings.
- Do not exceed gross vehicle weight or front/rear axle weights as specified in the vehicles Owners Manual and displayed on the Safety Certification Label located on the drivers door jam.
- Do not use weight distribution equipment.
- Use only the BMW X3 Ball Mount available from BMW centers with a maximum 2-inch Drop or  $\frac{3}{4}$  inch rise. Reference Illustration S71 03 U21.

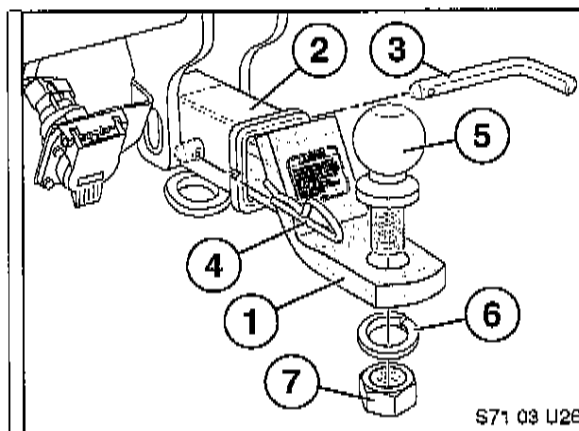
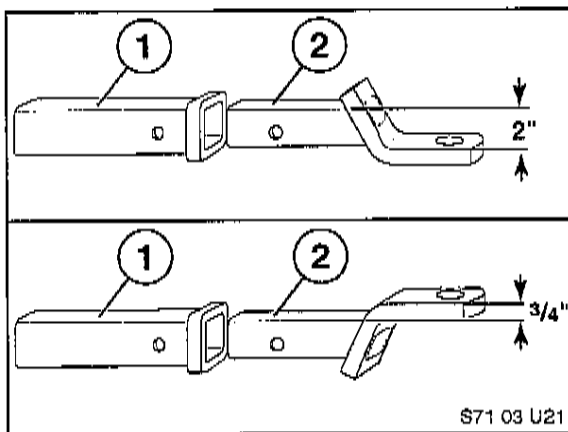

Install trailer ball (5) to ball mount (1) with lock washer (6) and nut (7).

**Important: Torque nut 250 foot lbs. (340Nm).**

Reference information and warnings on ball mount sticker.

Install ball mount assembly (1) into trailer hitch receiver tube (2) by aligning holes in mount and tube and inserting pin (3) and clip (4) as illustrated.

## BMW X3 Trailer Hitch Guidelines and Cautions

Page 2 of 2

These Guideline Sheets should be left in the vehicle (for customer reference) after installation of the Trailer Hitch

---

- Before attaching, loading, or towing a trailer please read the brochure (included with the installation kit, available from your BMW Center, available on line at the NHTSA Web Site [www.nhtsa.gov](http://www.nhtsa.gov) or available by calling the DOT Auto Safety Hotline at 888-327-4236): TOWING A TRAILER – Being Equipped for Safety, NHTSA Publication DOT HS 809 433, April 2002.
- Check all connections (mechanical and electrical) before and during the towing of a trailer.
- Check the function of all vehicle lights and the lights on the trailer before and during the towing of a trailer.
- Do not cut, weld, drill or modify the trailer hitch.
- Do not modify any wiring or electrical components.
- *Note:* Electric Brake for Trailer not connected as part of standard installation.

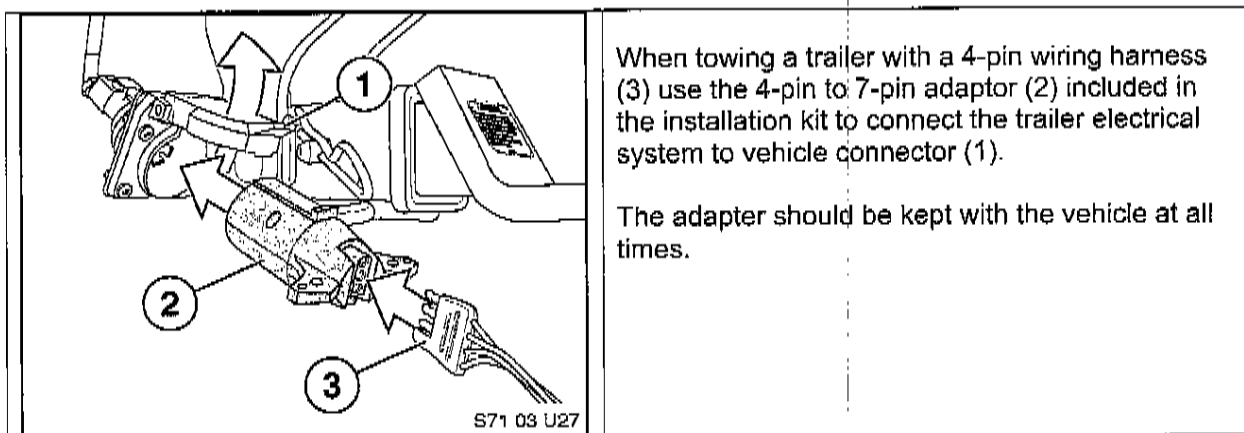

When towing a trailer with a 4-pin wiring harness (3) use the 4-pin to 7-pin adaptor (2) included in the installation kit to connect the trailer electrical system to vehicle connector (1).

The adaptor should be kept with the vehicle at all times.