Table of Contents

The DVOM

Subject	Page
Introducing the DVOM.....	3
Choosing a DVOM.....	3
The Functions.....	5
Rotary Switch.....	5
Push Button Functions.....	7
Input Terminals.....	9
Display.....	9
Infinity Display.....	10
Voltage Testing.....	11
Amperage Testing.....	12
Resistance Testing.....	13
Continuity Testing.....	14
Voltage Drop Testing.....	15
Worksheet.....	16
Testing Circuits.....	17
Worksheet.....	21
Review Questions.....	24

The DVOM

Model: All

Production Date: All

Objectives

After completing this module you should be able to:

- Choose a proper multimeter for testing.
- Correctly install a DVOM in a circuit for testing.
- Understand the use of a DVOM for electrical testing of circuits.
- Know how different types of circuits are tested.
- Complete and understand the following tests as performed on circuit boards:
 - Voltage
 - Amperage
 - Ohms
 - Voltage Drop Test

DVOM

Introducing The DVOM

The ability to measure voltage, current flow, and resistance is important in the diagnosing of electrical problems. Without the results of these measurements troubleshooting in an electrical system is a futile process.

The instrument most commonly used to make electrical measurements is called the Digital Voltage-Ohm Meter (DVOM).

Basic DVOM's are capable of measuring:

- AC Voltage
- Millivolts
- Conductance
- Continuity
- Amps/Milliamps
- DC Voltage
- Resistance
- Capacitance
- Diode Test
- Microamps

Advanced DVOM's add:

- Frequency
- Duty Cycle
- RPM
- Pulse Width

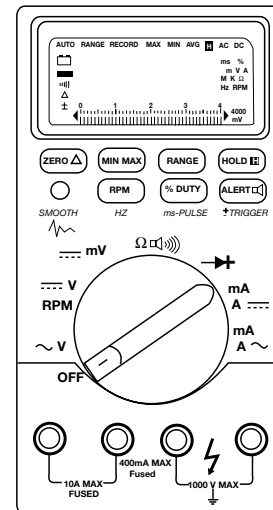

12510013c.eps

The DVOM provides for a method of accurate measurements.

Even though accurate measurements are the key to electrical diagnosis, the following four factors determine the effectiveness of the measurements:

- Accuracy of the measuring instrument.
- Correct installation in the circuit of the measuring instrument.
- Ability of the Technician to read the instrument.
- Skill of the Technician in interpreting the results.

As it is clearly seen, only one of the factors depends on the DVOM (e.g. accuracy), the rest will always depend the ability of the technician to read and interpret the results.

Choosing A DVOM

A good choice of a DVOM is the DISplus or the MoDic, as the measuring system of each contains a highly accurate DVOM.

Choosing a handheld DVOM from a reputable manufacturer, however, leaves the DISplus and MoDic free to perform other tasks that a DVOM can not do (e.g. Retrieval of fault codes).

In choosing a DVOM several factors need to be considered, one of which is **Impedance**.

Impedance is the combined resistance to current created by the resistance, capacitance and inductance of the meter. Impedance is measured in '**Ohms per Volt**'.

Meters with the highest '**Ohms per Volt**' impedance are the most accurate. More importantly using a meter with high impedance will not cause damage to sensitive electronic circuitry.

When a Meter is connected across a circuit to measure voltage, it must be connected in parallel. This adds parallel resistance. The total resistance in a parallel circuit is less than the lowest resistance in that circuit (Ohms Law). Using a Meter with low impedance will reduce the total resistance of the circuit and allow more current to flow.

A meter with low impedance can draw enough current to cause inaccurate measurement, voltage drops or damage sensitive electronic circuit boards. A high impedance meter will draw little current and insure accurate readings.

Using older type meters with low impedance values (20,000 to 30,000 ohms-per-volt) can damage modern electronic circuits and components or give inaccurate readings.

Test lights should be avoided for the same reason. They lower the total resistance of the circuit and cause increased current flow.

Other factors in choosing the proper DVOM are:

- Cost
- Features

Basic DVOM's are available reasonably priced. These basic models may be more than sufficient for use in BMW Centers, given the availability of the DISplus and MoDic for advanced measurement and scope functions.

Advanced features and price go hand in hand. The more features added the higher the cost. Some of those features may be worth the increase in cost (e.g. frequency, duty cycle and pulse width). Other features may not (e.g. oscilloscope, graphing).

Choose a DVOM wisely based on personal preference and cost. Like many other tools it is valuable in the diagnosis and repair of BMW's. Experience has shown if the technician is not comfortable with the DVOM or confident in the results of the measurements, the DVOM will not be used. Considering the technology in BMW automobiles, diagnosing with a quality DVOM certainly makes repairing the problem correctly and expediently a more manageable task.

The Functions

Function Selector Rotary Switch

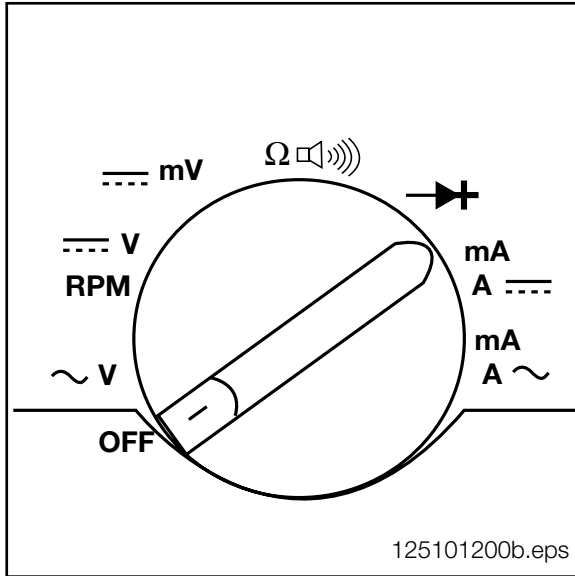

Power to the meter is turned off.

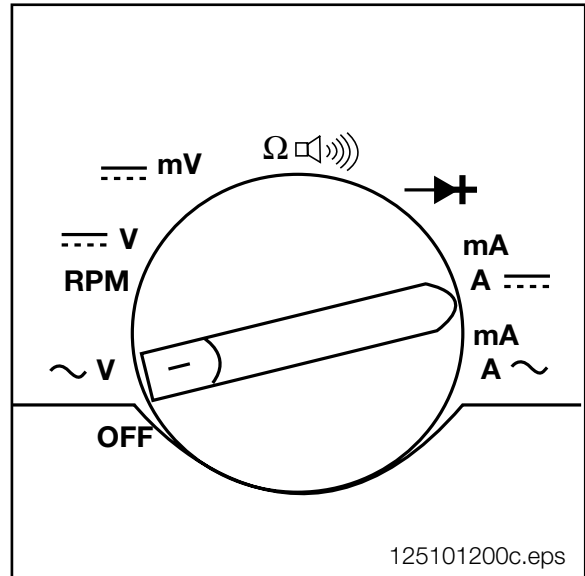

Volts AC
Measures AC Voltage
Ranges: 400mV, 4V, 400V, 1000V

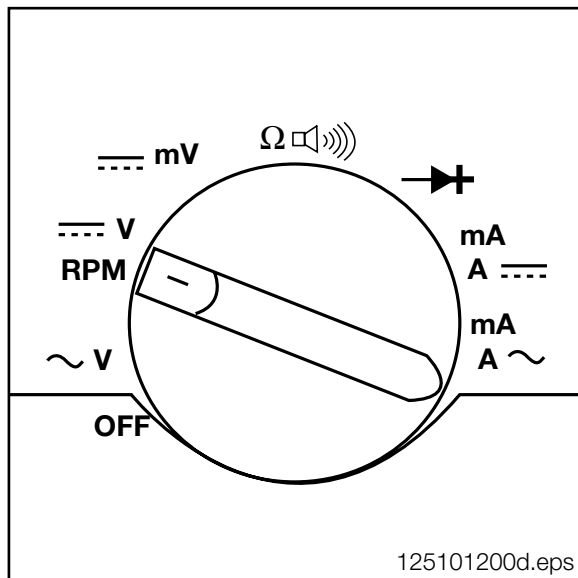

Volts DC, RPM
Measures DC Voltage
Ranges: 4V, 40V, 400V, 1000V

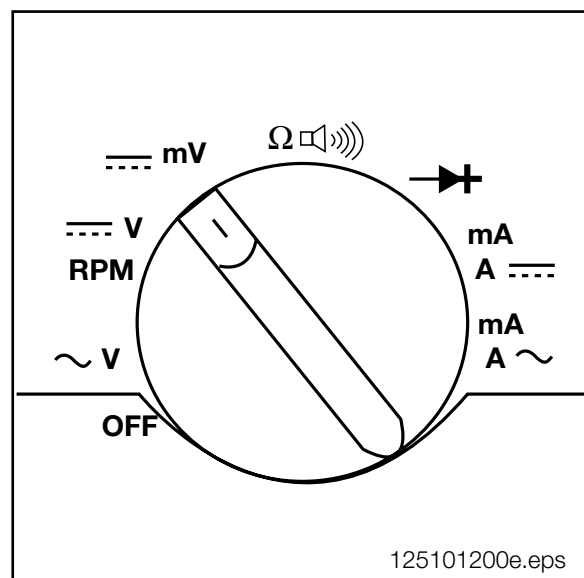

mV
Measures DC Millivolts
Range: 400mV

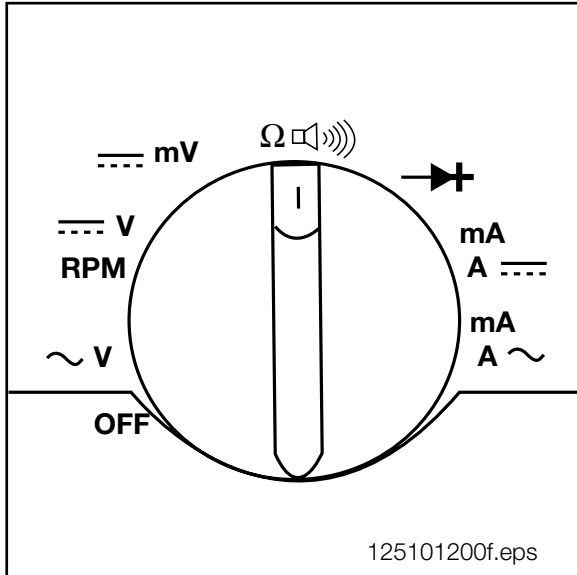

Continuity / Ohms
 Measures Continuity and Ohms.
 Ranges: 400Ω , $4k\Omega$, $400k\Omega$, $4M\Omega$, $40M\Omega$

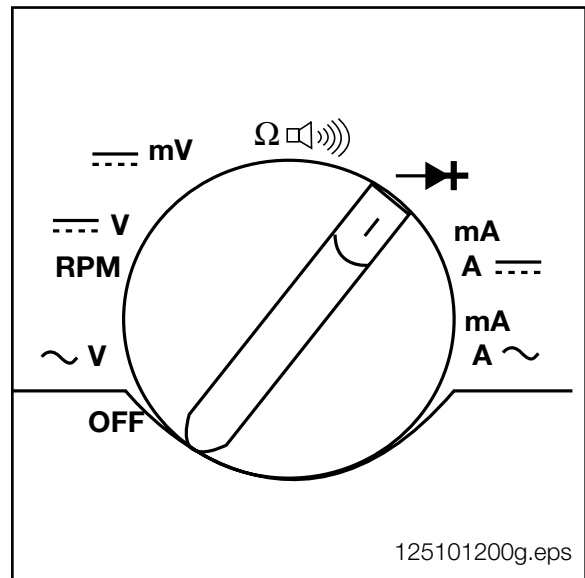

Diode Test
 Test diode operation.
 Range: 3.000V

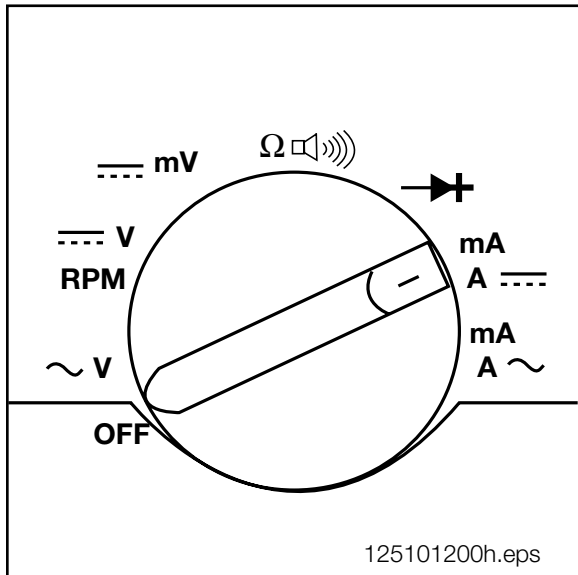

Milliamp or Amps DC
 Measures DC Milliamps or amps.
 Ranges: 40mA or 400mA for mA input
 4000mA or 10 A for A input

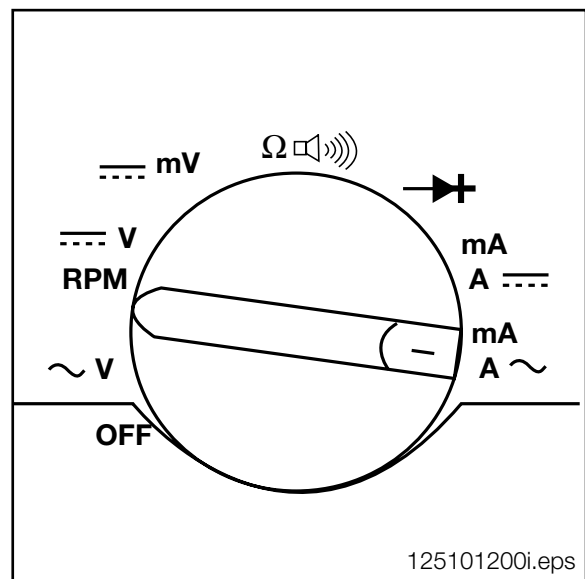

Milliamps or Amps AC
 Measures AC Milliamp or amps
 Ranges: 40mA or 400mA for mA input
 4000mA or 10 A for A input

Push Button Functions

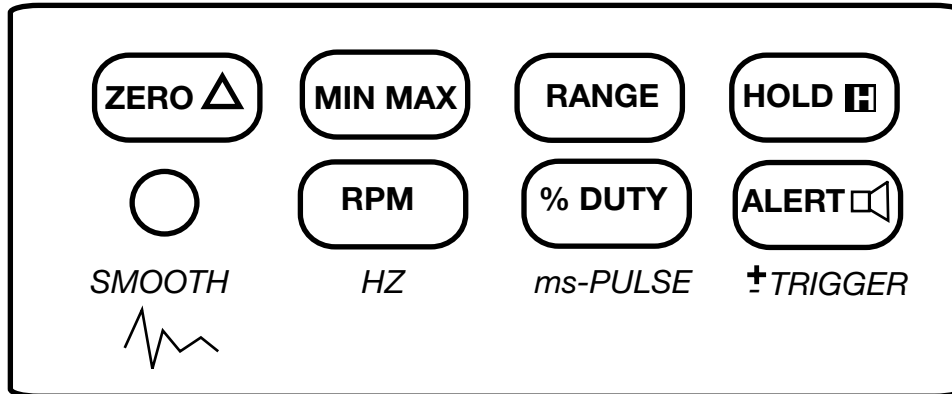

12510200.eps



125101200a.eps

Zero (Relative Reading) Function
Displays difference between the measured value and the stored value.



125101201b.eps

Minimum (Min), Maximum (Max), Average (AVG) Recording
Records minimum, maximum and calculates the true average.



125101202c.eps

Manual Range or Autorange
In Manual Range user selects fixed range. Meter stays in that range until user changes it, selects Autorange or turns meter off. In Autorange meter selects range automatically.



125101203.eps

Touch Hold
Touch Hold holds last stable reading on display. A new stable reading causes beeper to sound and display to update.

If meter is in MIN MAX Recording, RPM, Duty Cycle, Pulse Width or Hz, Touch Hold interrupts the function. The display is frozen, but recorded readings are not erased.



HZ

125101204.eps

RPM / HZ
RPM 2, RPM 1, or frequency
RPM 2, 4-cycle engines
RPM 1, 2-cycle engines
Hz. counts frequency between 0.5 Hz and 200 kHz.



ms-PULSE

125101205.eps

Duty Cycle or Pulse Width
Duty Cycle between 0.0 and 99.9% displayed.
Pulse Width between 0.002 and 1999.9 ms displayed.



± TRIGGER

125101206.eps

Change Alert, Continuity Beeper or +/- Trigger.

In voltage or current functions selects Change Alert.
In Ω function selects Continuity Tests.
In Duty Cycle or Pulse Width selects trigger slope.

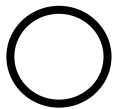

SMOOTH



125101207.eps

Smoothing Function and Back-light display (advance model only).
Smooth displays average of last eight readings.
Press Yellow button to turn on or off back-light.

Input Terminals

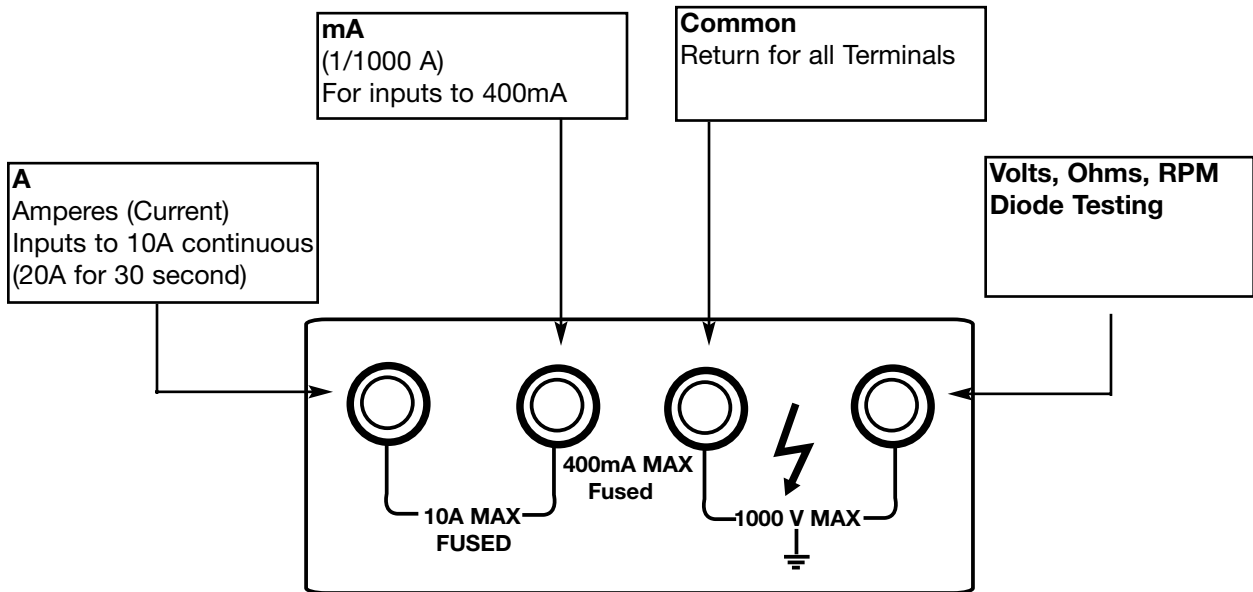

125101208.eps

Display

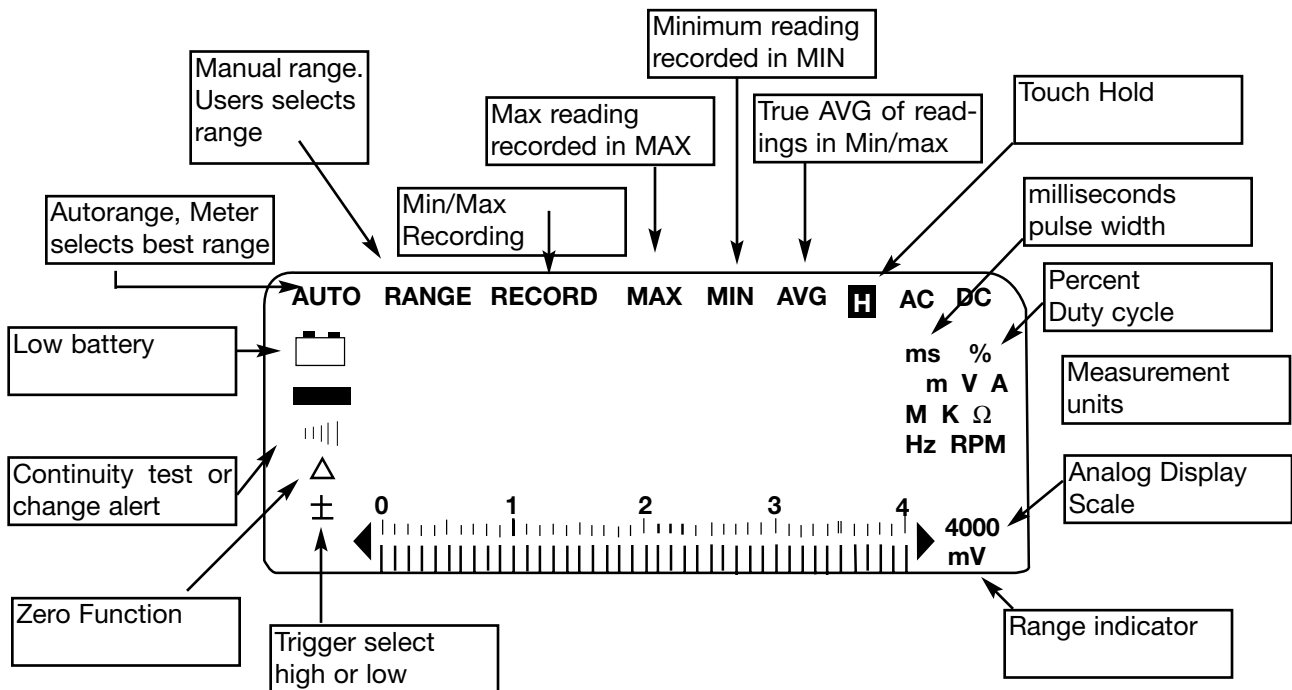

Infinity Display

While most displays of DVOMs are standard (i.e. mV means millivolt, mA means milliamp) the display or symbol for infinity or open circuit can be confusing. A display of 0Ω indicates no or little resistance. It means the circuit or portion of the circuit being measured has continuity or is complete. A reading of OL means the circuit is open or not complete, the resistance is said to be "INFINITY". Some meters may use the symbol ∞ for Infinity. Be aware of which reading the meter being used will give for infinity or open circuit.

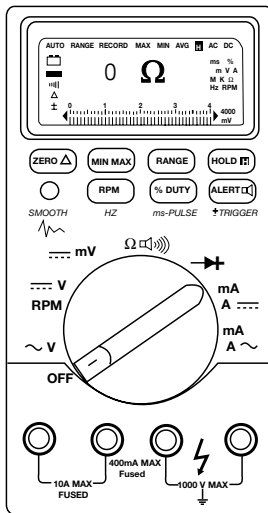

Meter 1

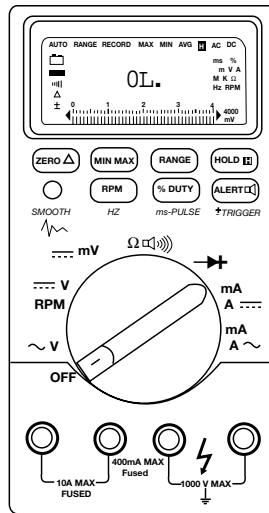

Meter 2

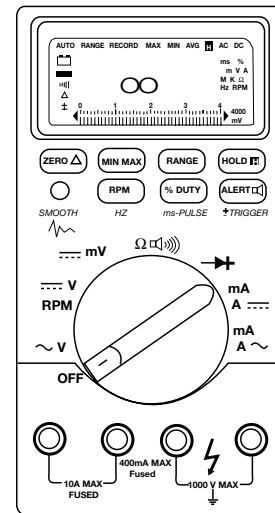

Meter 3

12510013a.eps

Using the DVOM

Voltage Testing

The voltmeter (DVOM) must be connected in parallel with the load or circuit.

The DVOM has a high resistance and taps off a small amount of current.

A voltmeter must be used with the current on and with the correct polarity.

The red lead should be connected to the B⁺ side of the circuit and the black lead to the B⁻ side of the circuit.

If the leads are reversed the reading will be a negative number.

Typical Application of Voltage Testing

- Checking Power Supply.
- Charging System.
- Complete Basic Circuits.
- Control Module Functions (Input/Output).

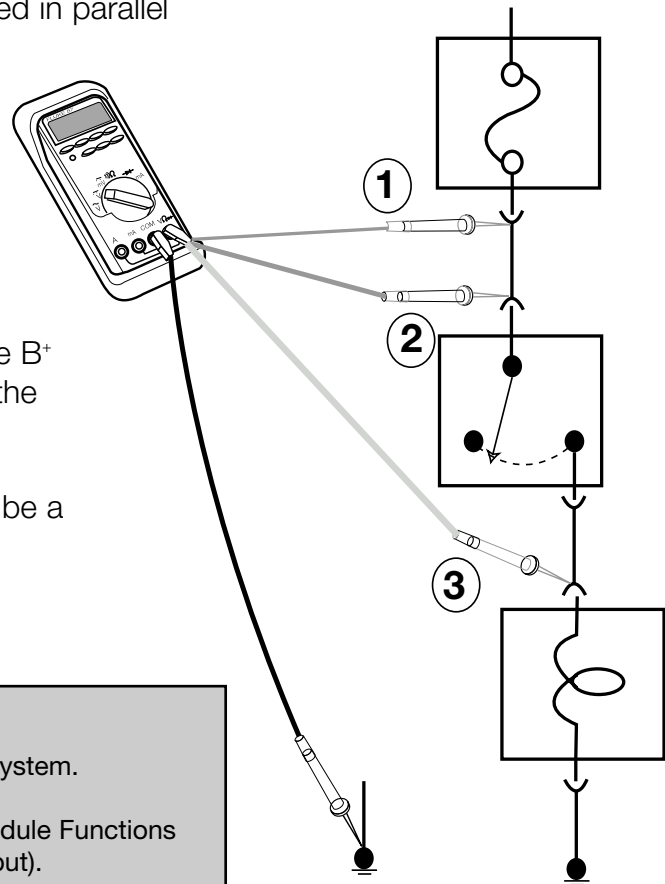

2510101a.eps

Measure at different points checking for change or interruption in the voltage supply.

- Select proper function and range of DVOM.
- Connect (-) lead of meter to battery B- or known good ground.
- Connect (+) lead of meter to test circuit.

DVOM will indicate supply or available voltage at that point.

Amperage Testing

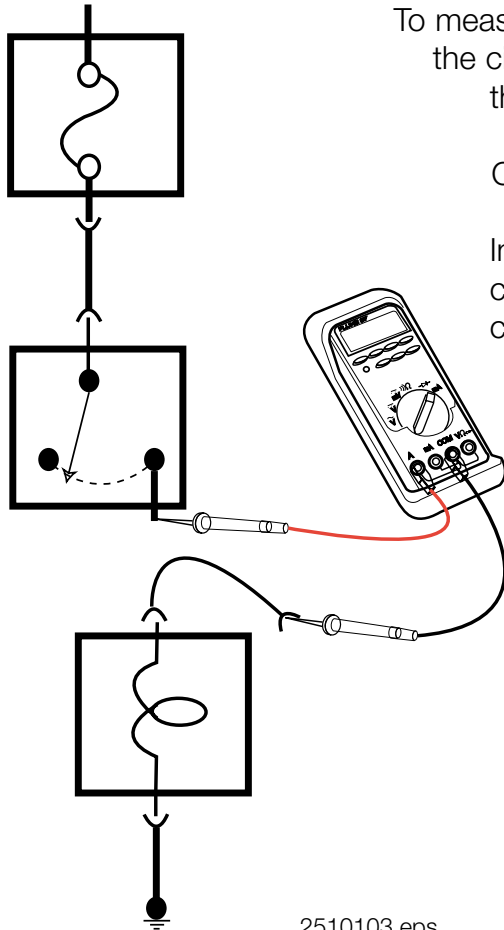

To measure amperage the meter must be installed in series in the circuit. The current flow of the circuit must flow through the meter itself.

Current must be flowing in the circuit.

Installing the meter in parallel with the circuit may cause damage to the meter, because of the increased current flow in the circuit, due to the low resistance in the meter.

Caution: Most ampere meters or DVOMs are rated for no more than 10 amps. Current flow above 10 amps will damage the internal fuse of the DVOM and render it unable to measure amperage.

Typical Application of Amperage Testing

- Proper Component Operation (Correct Current Draw).
- Parasitic Draw Testing.

Ensure meter is capable of handling current flow.
Use caution when activating additional consumers.

- Select proper function of DVOM and move leads to proper position.
- Connect meter in series with (+) lead on the B⁺ side of the circuit.
- Connect (-) lead of meter to complete circuit.

Note:

If the expected load may exceed the range of the meter, use a meter with a higher range (DISplus inductive pick-up) for initial testing.

Refer to ETM for convenient location to apply meter (e.g. across fuse terminals).

DVOM will indicate current flow (Amps) through circuit.

Resistance Testing

When set for resistance testing (Ohms) the DVOM must never be connected in a live circuit.

The component or portion of a circuit being measured, must be isolated from the power source.

Most modern day DVOM's are self ranging when set to measure resistance, so the meter can not be damaged by out of range measurements.

The test leads may be used without regard for polarity, unless the circuit contains a diode.

The DVOM functions by placing a very small amount of current on the circuit being tested, the red lead must be placed on the anode side of the diode.

Typical Application of Resistance Testing

- Locating a Short to Ground (As Shown).
- Determining Resistance of Components (e.g. Temp Sensors and Injectors).

- Select correct function and range (Most meters are self ranging in this function).
- Disconnect power to circuit.
- Disconnect any circuit wired in parallel with circuit being tested.
- Connect test leads.

Note:

There must be **NO** current available to the circuit during the resistance (Ohmic) test.

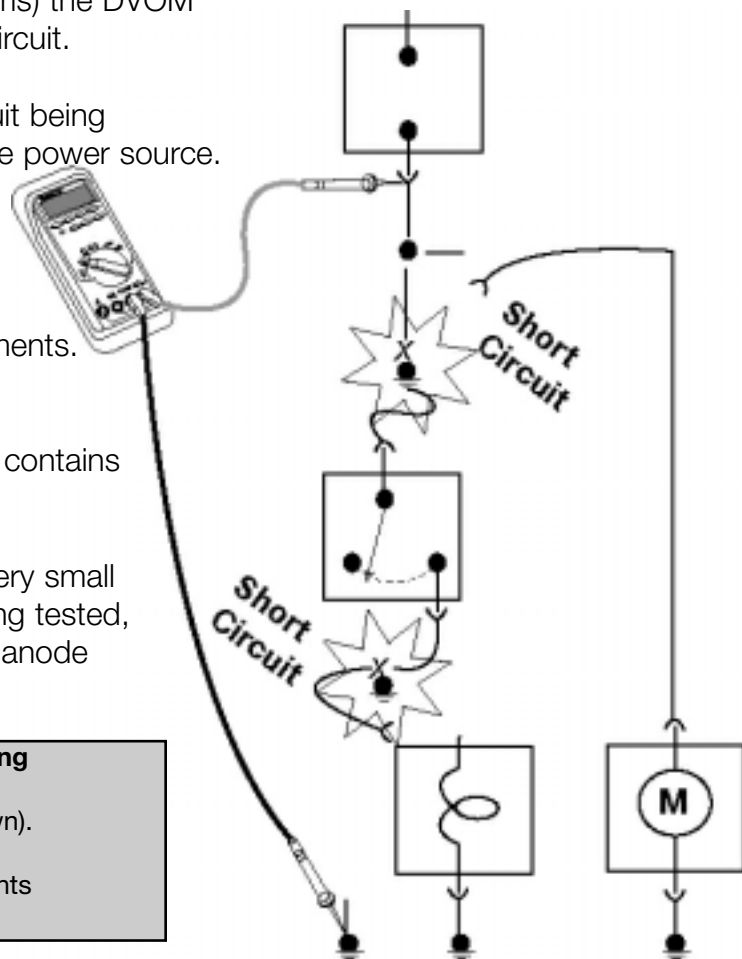

2510109a.eps

An Ohmmeter uses its internal power to test a circuit or component.

DVOM will indicate resistance (Ohms) of component or circuit being tested.

Continuity Testing

The DVOM may have a separate setting for continuity testing.

When set for continuity testing the DVOM must never be connected in a live circuit.

The power source must be disconnected from the circuit being tested. Any circuits wired in parallel with the circuit being tested must also be disconnected.

The DVOM uses its own internal power supply to test the continuity of the circuit.

Continuity testing verifies that circuit connections are intact. The continuity mode is extremely fast and is used to detect either shorts or opens that last as little as 1ms.

When a change is detected the beeper tone is stretched to last at least 1/4 second so both shorts and opens can be audibly detected.

This is a valuable troubleshooting aid when diagnosing intermittent faults associated with wiring, connections, switches and other components of the circuit.

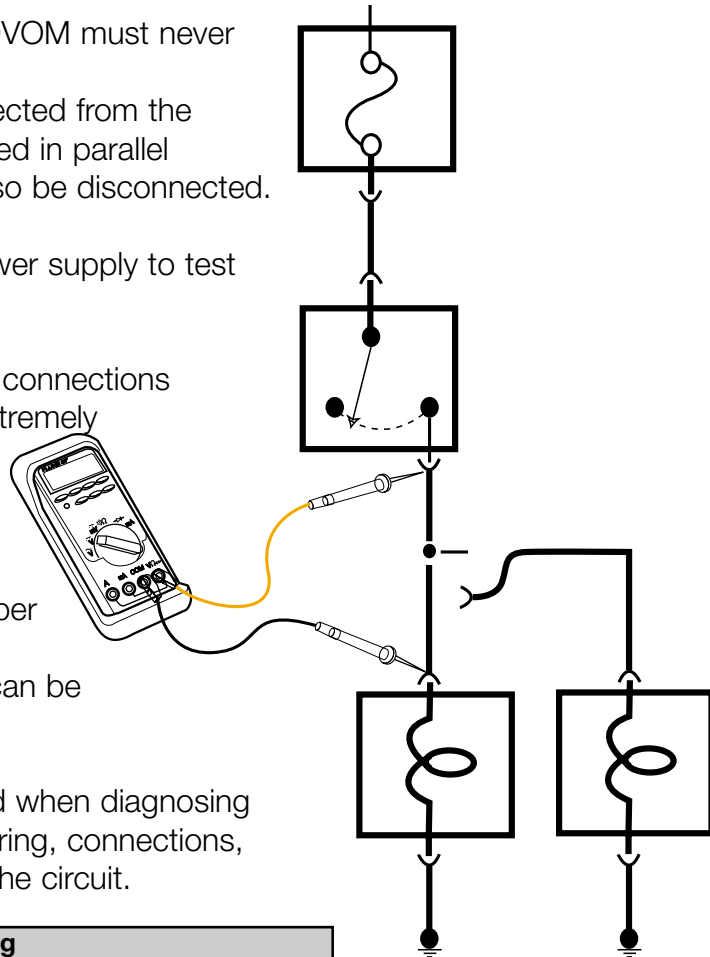

2510104.eps

Typical Application of Continuity Testing

- Circuit Continuity.
- Intermittent Wiring Harness Faults.

- Select correct function and range of DVOM.
- Disconnect power to the circuit.
- Disconnect any circuits wired in parallel.
- Connect DVOM leads to the circuit to be tested.

Note:

There must be **NO** current available to the circuit during the continuity test.

DVOM display will indicate continuity of circuit.

Voltage Drop Testing

Voltage Drop Tests determine the resistance of an active circuit, a circuit with current flowing.

Voltage drop tests are preferred over simple resistance measurements because the power source is not removed from the circuit.

By measuring the voltage on both sides of a load, the amount of voltage consumed by the load is measured.

The voltage drops of each part of a series circuit added together must equal the power supply for that circuit while it is active.

Typical Application of Voltage Drop Testing

- Determine proper component operation.
- Active circuit continuity.
- Active circuit resistance.

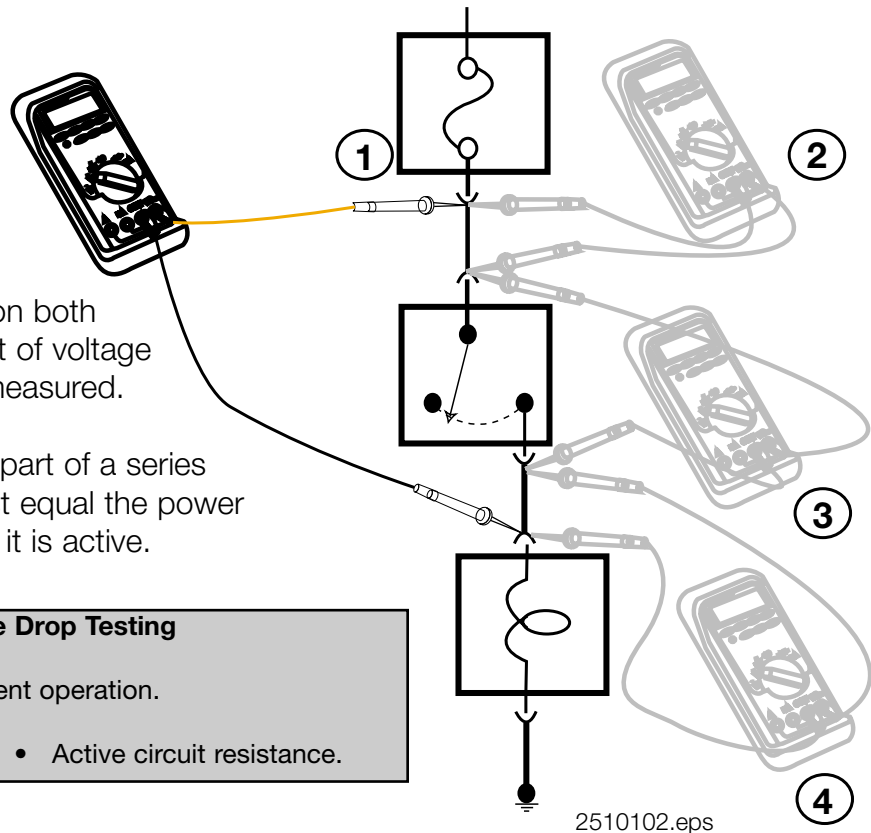

As a “Dynamic” test with the circuit operational, a voltage drop in any non-resistive part of the circuit indicates a fault in the circuit,

- Select proper function and range of DVOM.
- Connect (+) lead to the B+ side of the circuit or component being tested.
- Connect (-) lead to the B- side of the circuit or component.

Note:

All consumers of the test circuit should be active during the test.
Always include ground circuit as part of voltage drop test.

DVOM display will indicate the voltage drop in the circuit tested between the DVOM leads.

Worksheet

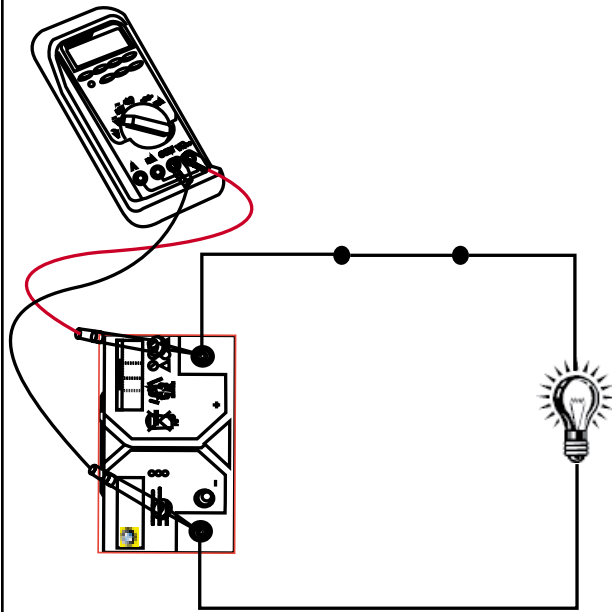

125101078.eps

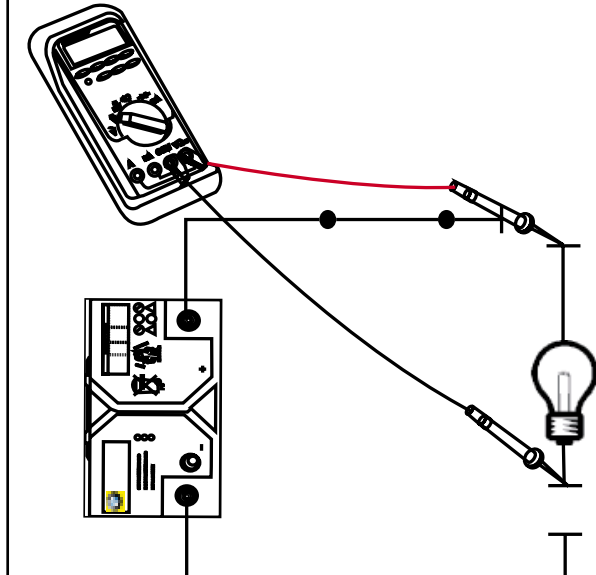

12510179.eps

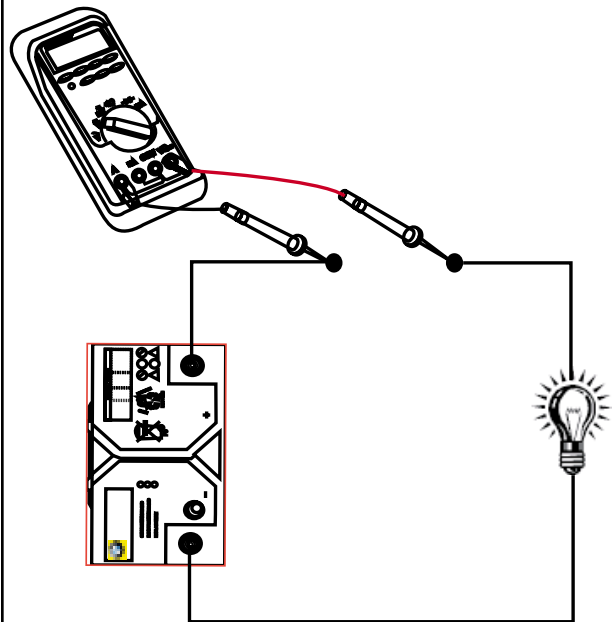

12510180.eps

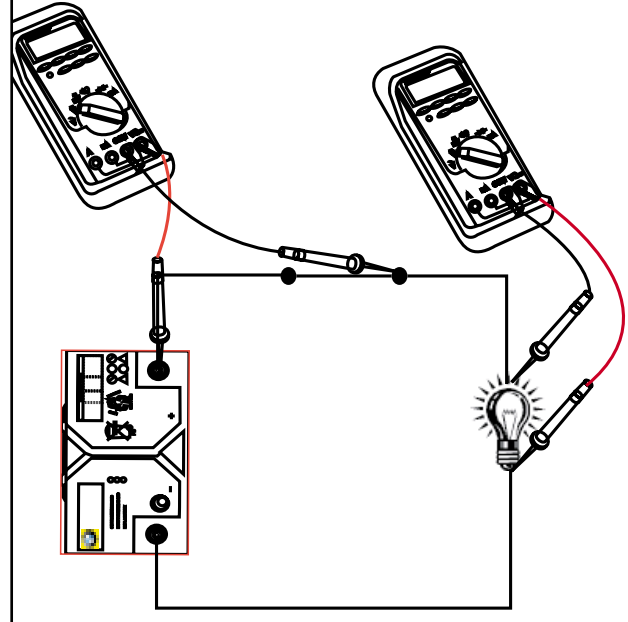

12510181.eps

Label the Picture with the proper test name..

Testing Circuits

Circuit 1

Build this circuit per Wiring diagram. Use one bulb initially, second bulb will be added.

Do not turn on power supply until instructed.

Before applying power check voltage of power supply.

- Measure resistance of one bulb. _____
- Turn on power supply. Measure voltage drop across entire circuit. _____
- Measure voltage drop across bulb. _____
- Measure amperage of the circuit. _____
- Measure the resistance across a second bulb. _____
- Install the second bulb. Measure amperage of the circuit. _____
- How did the amperage change? _____ Why? _____
- Measure the voltage drop across each bulb. _____
- Check voltage drop across top of fuse. (Third from right) _____
- Remove fuse and check voltage drop across fuse terminals. _____
- What type of circuit is this? _____

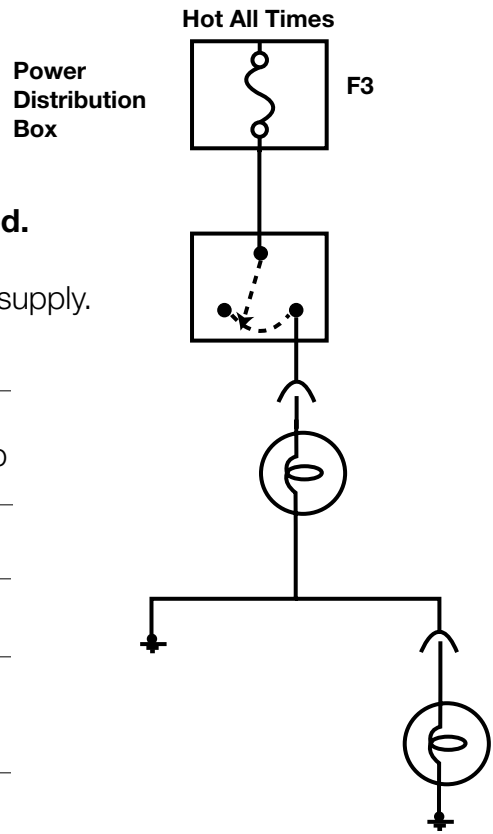

125101206.eps

12510183b.jpeg

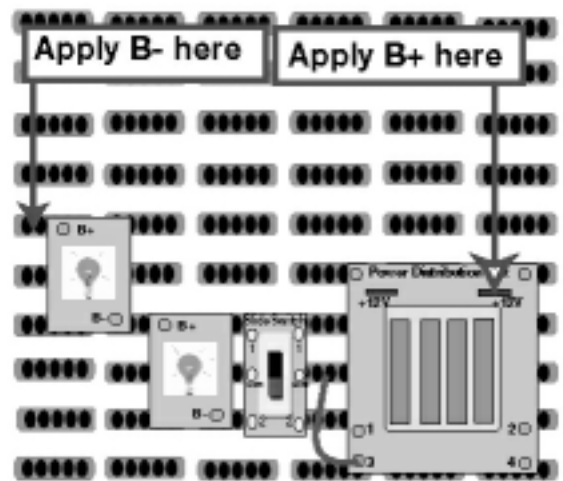

Completed circuit should look similar to this.

STOP DO NOT DISASSEMBLE CIRCUIT

Circuit 2

Build this circuit using the Wiring diagram.

Be sure the power is OFF.

- What should the voltage be at points 1 and 2 ? _____
(Do not measure)
- What should the voltage be at points 3 and 4 ? _____
(Do not measure)
- Turn on the power supply. Measure voltage at 1. _____ 2. _____
- Measure voltage drop B 1. _____
- Measure voltage drop across both bulbs in each leg of circuit. _____
- Measure amperage in bulbs B1/B3. _____
- Estimate the total amperage of the circuit. _____
How was the answer calculated? _____
- Measure total circuit amperage. _____
- Remove bulb B4 from circuit.
- Measure amperage on circuit with only one bulb burning. _____
- What is the effect on the total circuit amperage. _____
- What type of circuit is this? _____

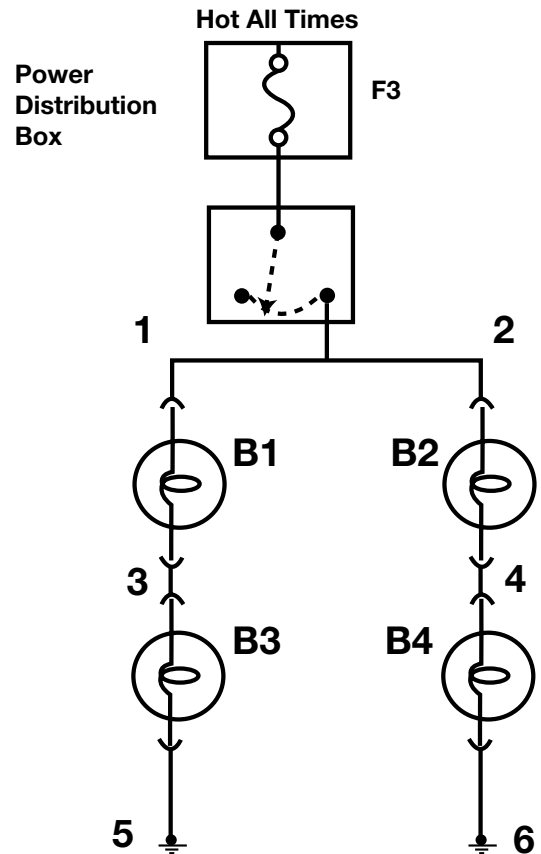

125101207.eps

12510184b.jpeg

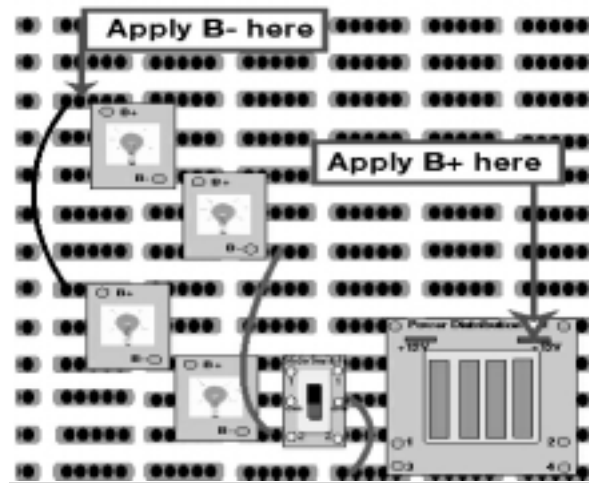

Completed circuit should look similar to this.

Circuit 3

Remove all light bulbs and jumpers leaving the power distribution box and switch.

Be sure power is off.

Build circuit per wiring diagram.

DO NOT APPLY POWER AT THIS TIME.

- Measure resistance of each resistor at resistor. _____
- Measure resistance between Pin 3 on Power Distribution Box (PDB) and Pin 2 on Resistor Pack (RP).

- Are the resistors wired in series or parallel?

- Turn on power, measure voltage at power supply. _____
Turn off power supply.
- Using Ohms' law, calculate the amperage of the circuit at RP Pin 3. _____
RP Pin 2. _____
- Turn on power supply and switch. Measure the amperage at RP Pin 3. _____
RP Pin 2 _____
- With B- applied at RP Pin3 what is the voltage drop at RP Pin 3 and PDB ? _____
RP Pin 2 and PDB ? _____
- Move B- to RP Pin 2 and re-measure voltage drops. _____
- Turn off power supply. Why did the voltage drops differ? _____

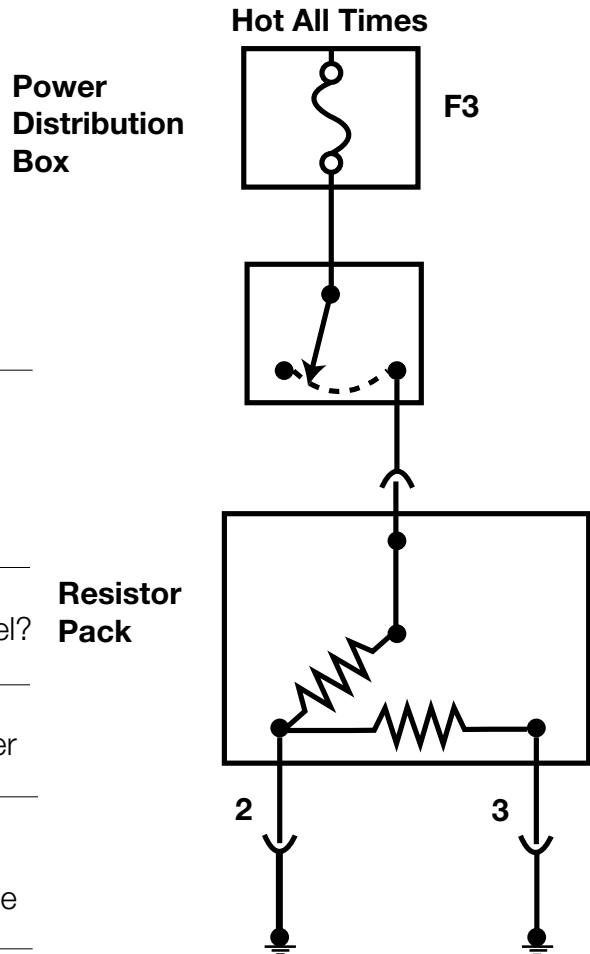

125101208.eps

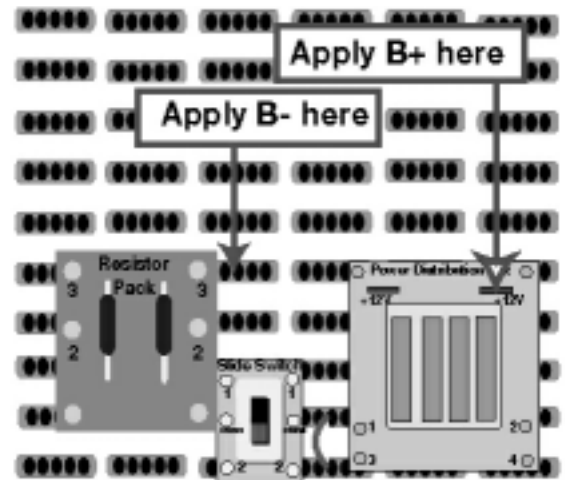

12510185a.jpeg

Completed circuit should look similar to this.

Circuit 4

Build circuit per wiring diagram.

- With power off, Switch in down position measure resistance between Pin 2 and Com of slide switch.

Slide switch to up position, measure resistance between Pin 1 and Com. _____

- Turn on power, put slide switch in up position.
- Measure supply voltage at PDB Pins 1/3. _____
- Measure voltage at Pin 86 of relay. _____

- Measure voltage drop between pins 86/85 of relay.(Switch in down position)

- Check voltage drop between pins 30/87 of relay. _____
- Push down button on push button switch and hold. Recheck voltage drops on relay pins 86/85. _____ 30/87. _____

What happened to the voltage drops? _____

- Move red jumper from Pin 2 of slide switch to Pin 1 of slide switch. Put switch in up position. Measure amperage of circuit. _____ (Only two bulbs should be burning.) Push button on switch. (All lights should burn) Measure amperage. _____

- Continue pushing button, check voltage drop Pin 86 of relay to B- _____ What happened ? _____

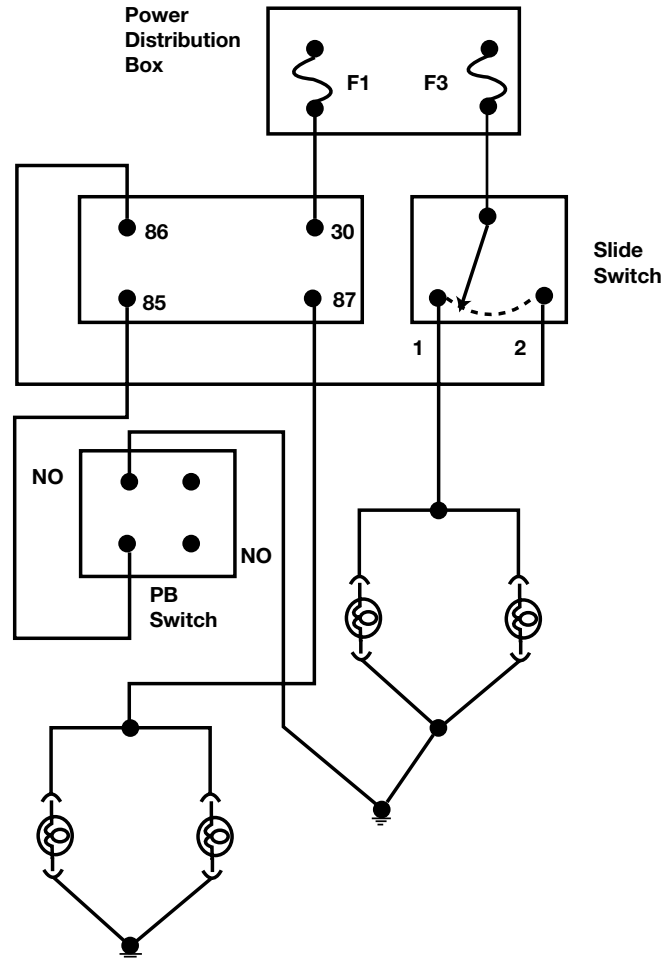

125101209.eps

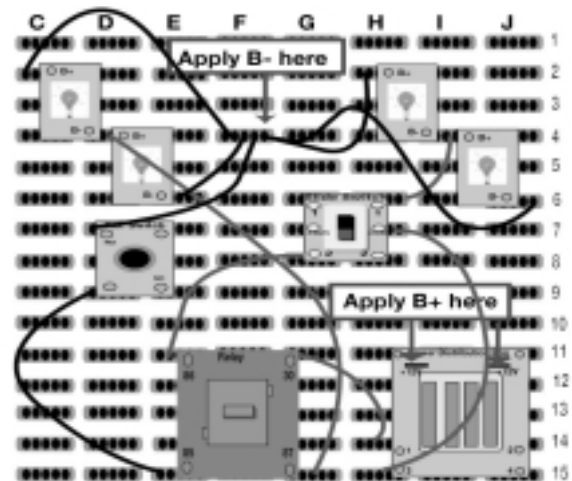

12510187.jpeg

Completed circuit should look similar to this.

Worksheet

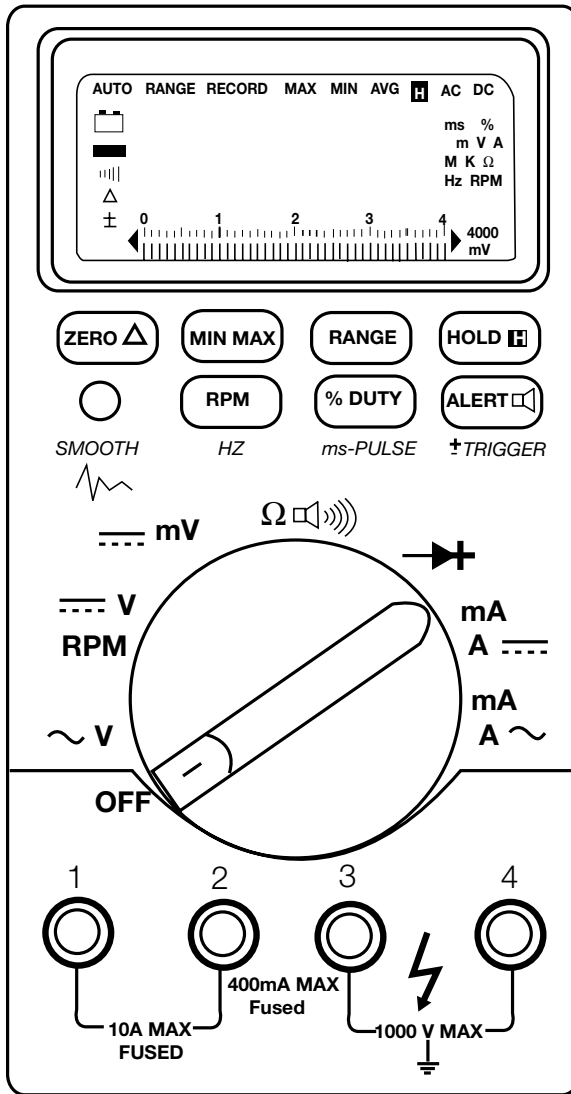

Tip on Using a DVOM

Inspect test leads and replace damaged leads.

Do not use a meter if it looks damaged.

Select the proper range and function for your test.

Disconnect the live test lead before disconnecting the common lead.

When measuring current, turn the power off in the circuit before connecting the meter.

Check meter fuse(s).

12510013a.eps

To Measure	Red Lead	Black Lead	Rotary Switch
AC voltage			
DC millivolts			
DC voltage			
AC milliamps			
AC amps			
DC milliamps			
DC Amps			
Ohms			
Diode Test			

NOTE: Some meters may have leads and functions in different locations
 Explanation of more advanced features of your DVOM can be obtained in the Users Manual

Worksheet

1.

Vehicle Model: _____

Customer Complaint: Vehicle does not start.

Measure Battery Voltage at Jumper Terminal: _____

Measure Voltage at Battery: _____

Measure Voltage Drop on Battery Cable: _____

Correction: _____

2.

Vehicle Model: _____

Customer Complaint: Rear window defogger does not work.

Measure voltage at fuse: _____

Measure voltage at term 30 of relay: _____

Ohm wire from fuse to relay: _____

Correction: _____

3.

Vehicle Model: _____

Measure amperage draw of rear washer pump: _____

Measure amperage draw of front washer pump: _____

4.

Vehicle Model: _____

Measure primary resistance of ignition coil: _____

What is the nominal value for the ignition coil: _____

5.

Vehicle Model: _____

Measure the amperage draw of the fuel pump: _____

Where is the best place to make this measurement: _____

What is the nominal value of this measurement: _____

6.

Vehicle Model: _____

Measure the voltage drop across the workside of the fuel pump relay with the pump not running: _____

Measure the voltage drop across the relay with the pump running: _____

7.

Vehicle Model: _____

Measure continuity of wire from DME to Injector #1: _____

Measure the resistance of this wire: _____

8.

Vehicle Model: _____

Measure voltage drop on B+ cable to starter: _____

Measure voltage drop on B- cable at Battery: _____

Measure amperage draw on starter: _____

Questions:

Review Questions

1. What are the four main factors that determine accuracy of electrical measurements?

2. What is the importance of impedance in a multimeter? _____

3. What does a meter reading of **OL** indicate during Ohms measurement? _____

4. What is the correct procedure for measuring amps and does this differ from other measurements ? _____

5. Why should test lights be avoided? _____
6. What happens if the leads are reversed while measuring Ohms of a circuit which includes a diode? _____
7. Why are voltage drop tests preferred over ohms tests? _____

8. How many amps are indicated by a meter reading of 238mA ? _____
9. What does a voltage drop reading of 12.6v across relay terminals 86 and 85 indicate?

What would the expected the voltage drop be across 30 and 87 at the same time ?

10. When measuring voltage, how is a meter connected to the circuit? _____
11. Where will the red lead be installed in the meter when measuring mA? _____
When measuring amps? _____
12. What would a voltage drop of 12.6v across a fuse indicate? _____